



# INSTALLATION INSTRUCTIONS

Accessory

STEERING WHEEL  
P/N 08U97-TX4-200

Application

2014 RDX

Publications No.

BII 48873

Issue Date

MARCH 2013

## PARTS LIST

Steering wheel



2 TORX bolts

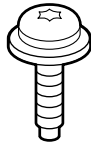

Steering wheel bolt



Information

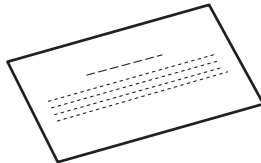

## TOOLS AND SUPPLIES REQUIRED

Phillips screwdriver

10 mm Open end wrench

10 mm Hex bit

Ratchet

T30 TORX bit

Torque wrench

Steering wheel puller

HDS

*The following tool is available through the Honda Tool and Equipment Program. On the iN, click on: Service > Service Bay > Tool and Equipment Program, then enter the number under "Search." Or, call 888-424-6857.*

Plastic Trim Tool (T/N SILTRIMTL10)

## Illustration of the Steering Wheel in the Vehicle

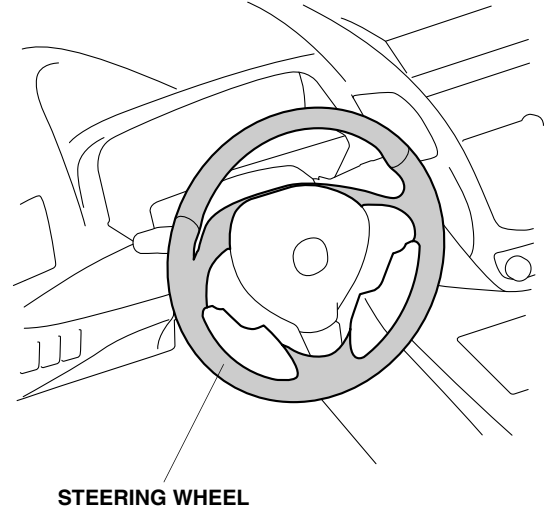

## INSTALLATION

**Client Information:** The information in this installation instruction is intended for use only by skilled technicians who have the proper tools, equipment, and training to correctly and safely add equipment to your vehicle. These procedures should not be attempted by "do-it-yourselfers."

### NOTE:

- Observe all safety notes and precautions in the service manual in addition to those in this installation instruction.
  - Be careful not to damage the vehicle.
  - After installing the steering wheel, you must align the steering wheel spoke angle to the straight ahead position by adjusting the front toe.
1. Turn the steering wheel so the front wheels are in the straight-ahead position.
  2. Disconnect the negative cable from the battery, and wait at least 3 minutes before you start to install the steering wheel.

3. Remove the access panel from the underside of the steering wheel.

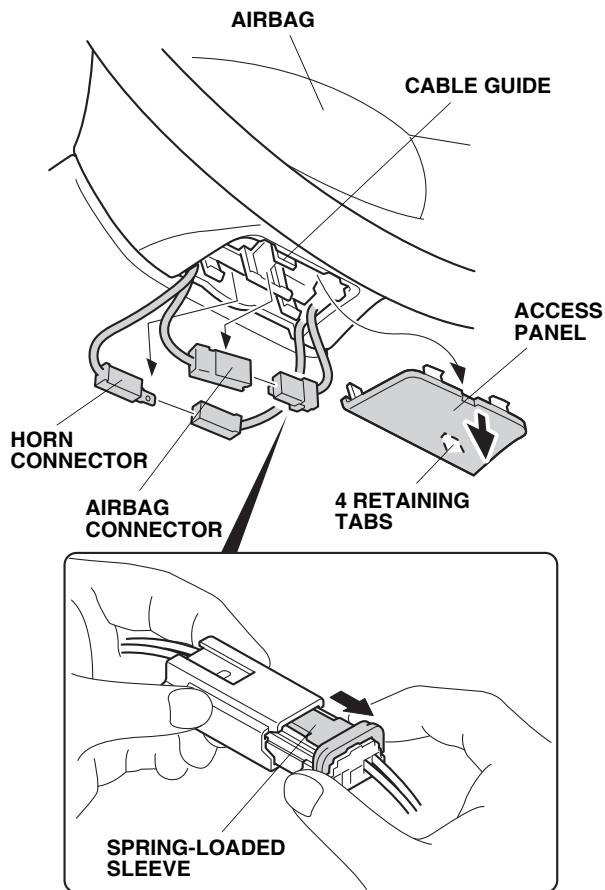

6. Remove the airbag (two TORX bolts). Do not drop the removed airbag or hit it on anything. Place the removed airbag in a safe place with the pad surface (top) facing upward.

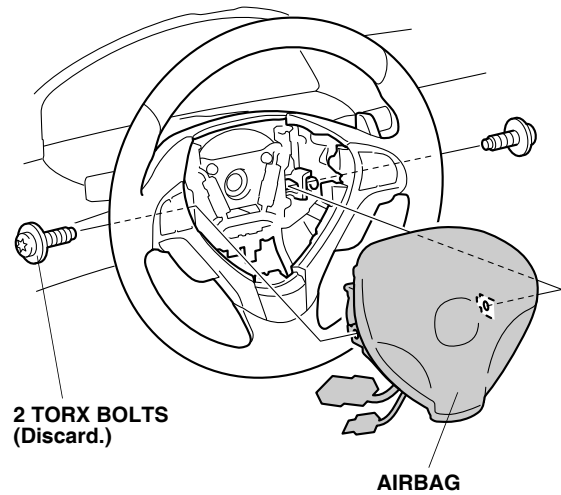

4. Remove the horn connectors from the cable guide and unplug the horn connectors.
5. Remove the airbag connectors from the cable guide and unplug the airbag connectors. To unplug the airbag connectors, pull the spring-loaded sleeve toward the stop while holding the opposite half of the airbag connector, then pull the airbag connector halves apart. Pull on the sleeve and not on the harness wires.

- Unplug the vehicle connector from the cable reel, and loosen the steering wheel bolt.

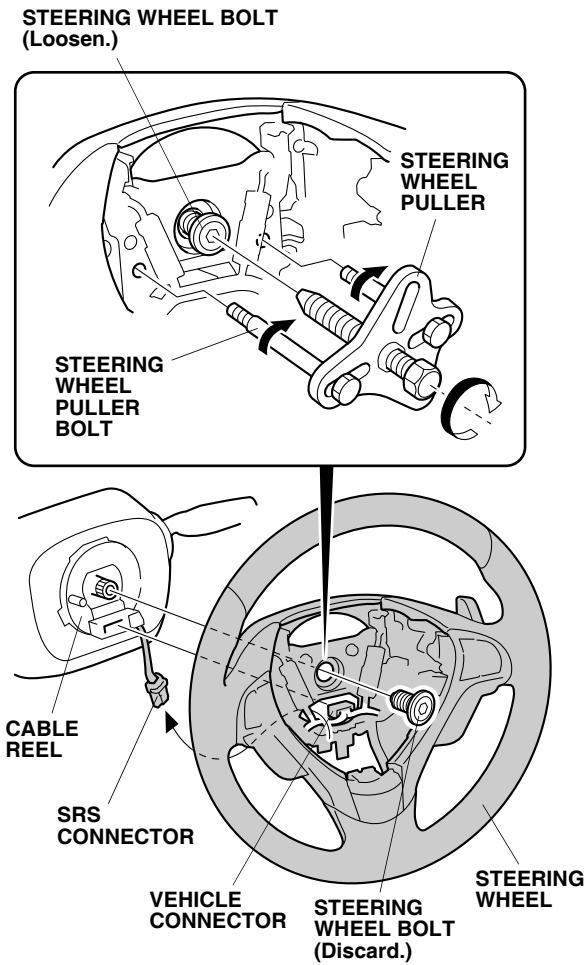

- Using a steering wheel puller, remove the steering wheel. Do not thread the steering wheel puller bolts in more than 10 mm. Be careful not to rotate the steering wheel during removal.
- Remove the steering wheel bolt, then remove the steering wheel.

- Remove the steering wheel cover (four screws).

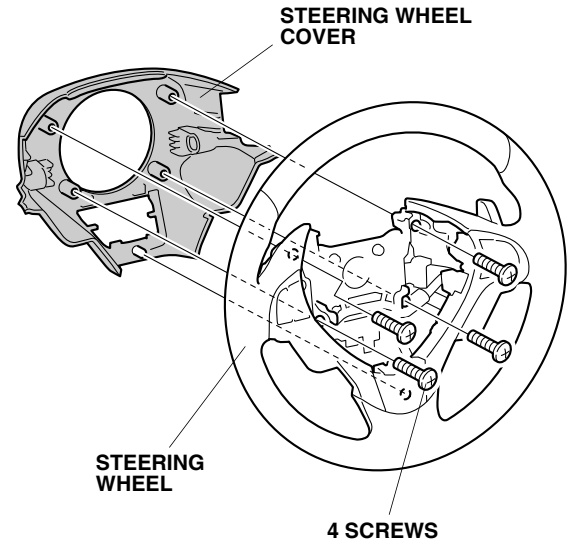

- Remove the lower cover (two screws).

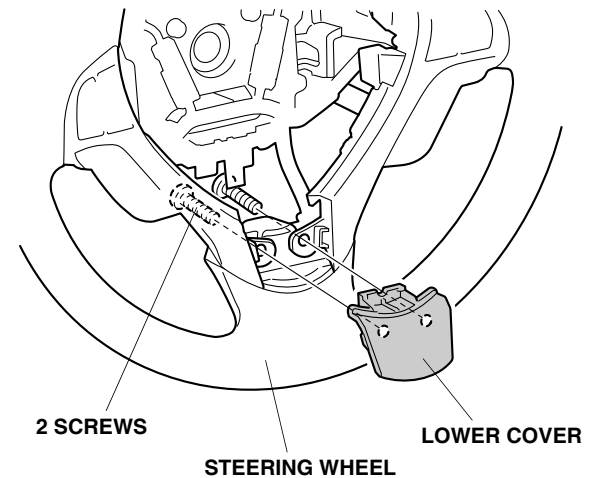

12. Remove the four screws from the left and right paddle switches.

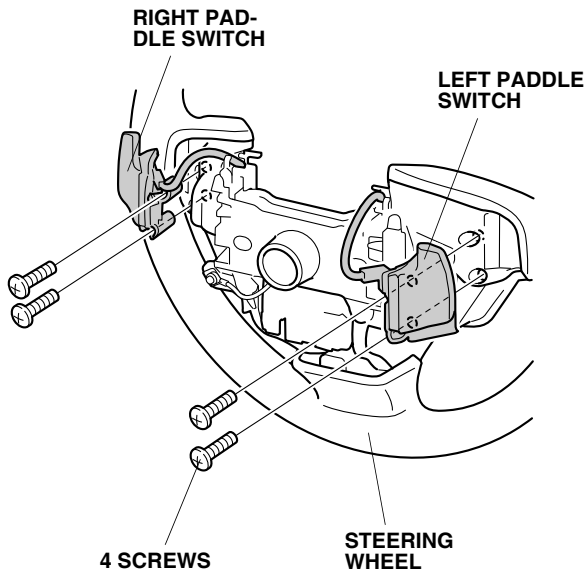

13. Remove the two screws.

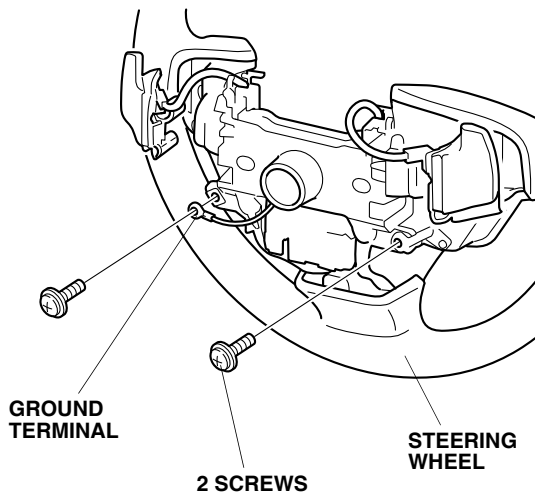

14. Remove the cable guide assembly (including both paddle switches, the audio switch, and the cruise switch) from the steering wheel (four retaining tabs).

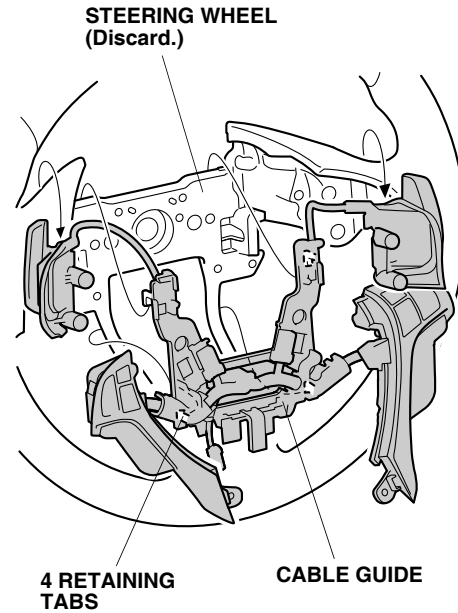

15. Install the cable guide assembly onto the new steering wheel.

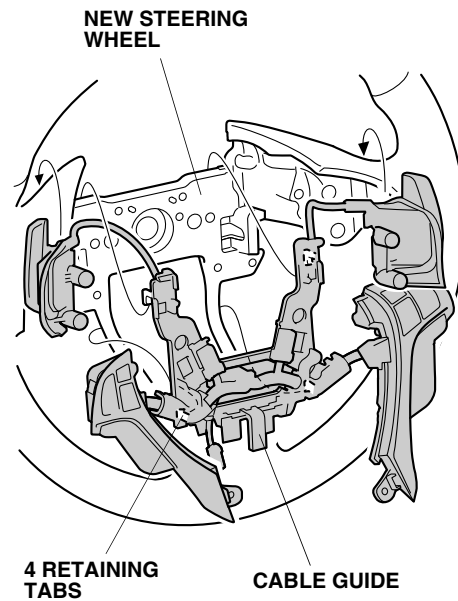

16. Install the two screws and ground terminal.

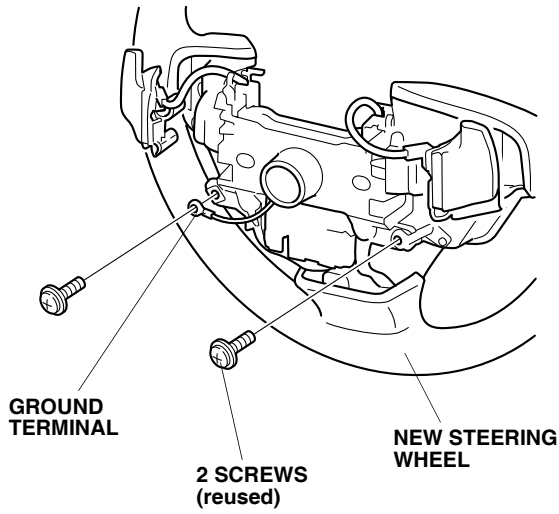

17. Install the left and right paddle switches to the new steering wheel with four screws.

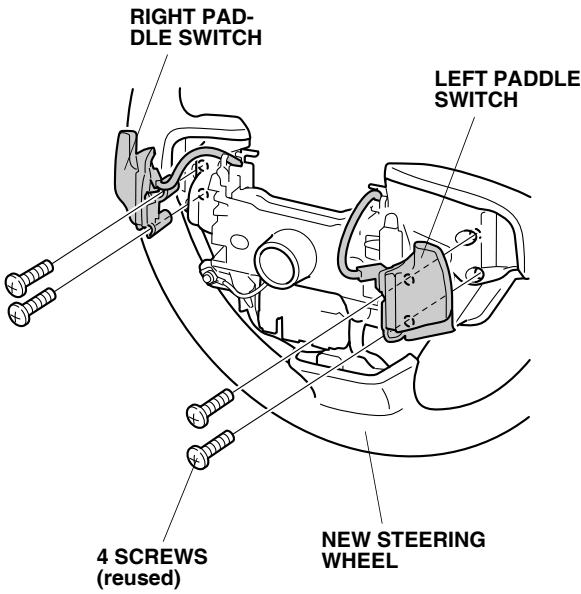

18. Install the lower cover to the new steering wheel with two screws.

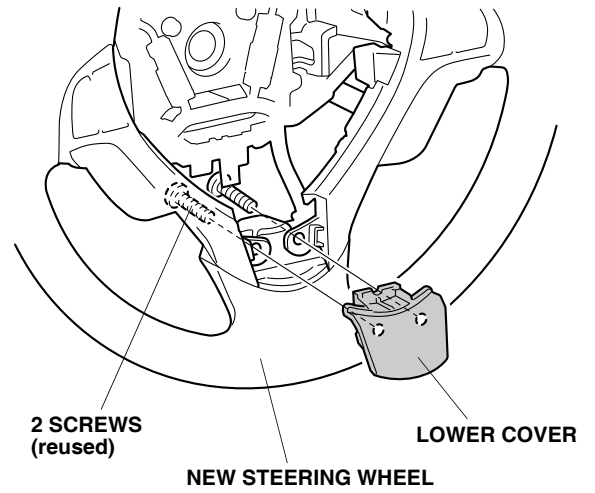

19. Install the steering wheel cover to the new steering wheel with four screws.

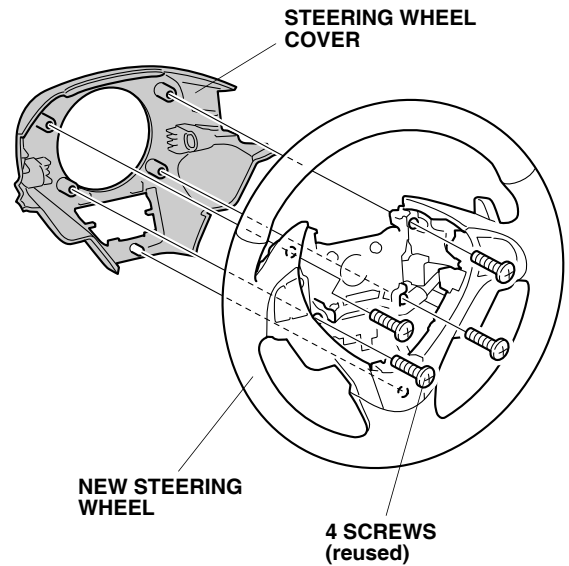

If the cable reel was moved, continue with step 20. If it was not moved, go to step 21.

20. Center the cable reel:

- Rotate the cable reel clockwise all the way until it stops.
- Rotate the cable reel counterclockwise about three full turns until the arrow mark on the cable reel points up.

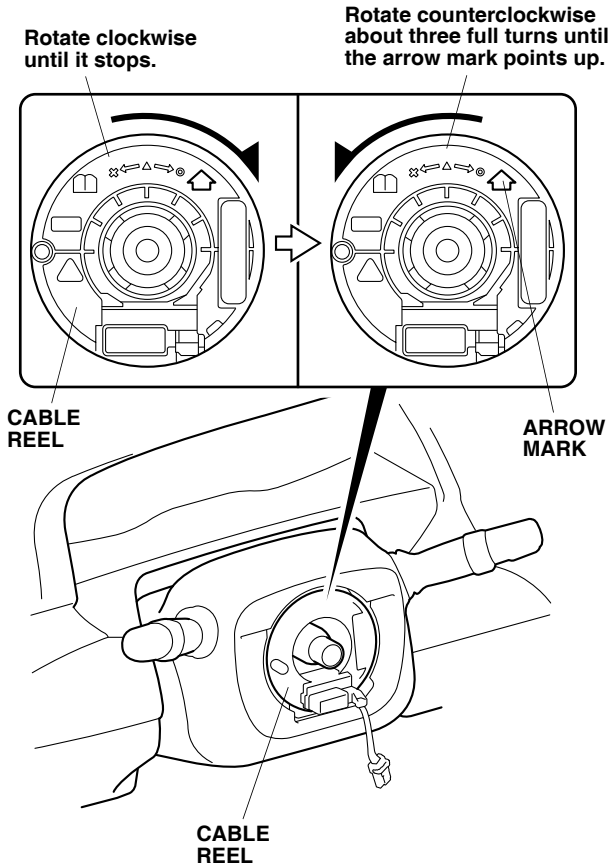

21. Route the airbag connector through the opening in the new steering wheel, then install the steering wheel to the steering column shaft in the straight-ahead position: Make sure the wire harnesses are not pinched.

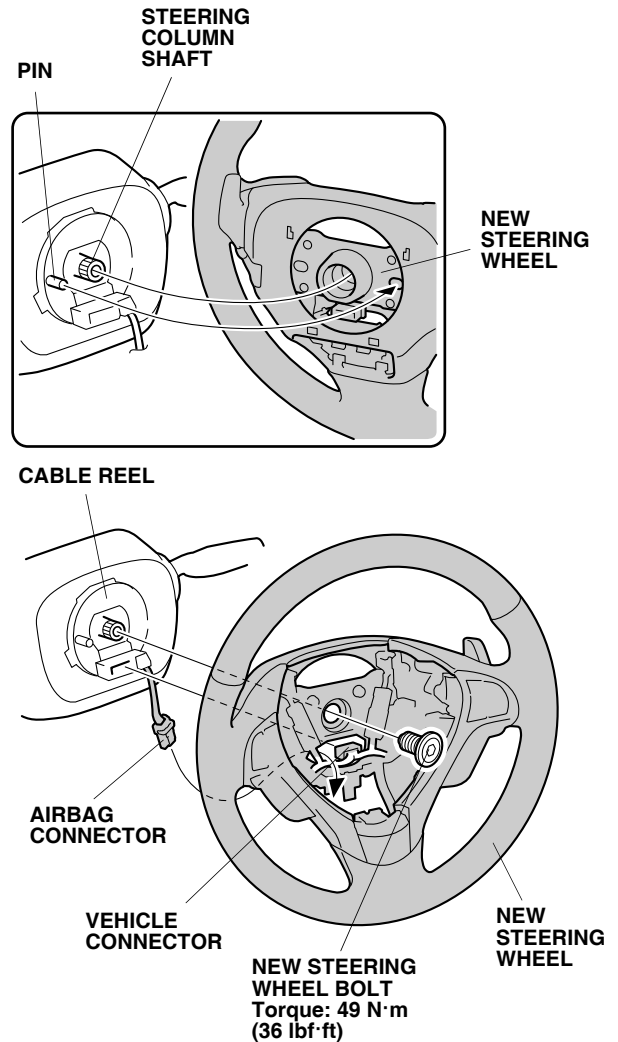

22. Install the new steering wheel bolt. Torque the new steering wheel bolt to 49 N·m (36 lbf·ft).

NOTE: The original steering wheel bolt is coated with locktite, and cannot be reused. When installing the new steering wheel, use the steering wheel bolt included in the kit.

23. Plug the vehicle connector into the cable reel.
24. Install the airbag on the new steering wheel.
  - Make sure that the harness does not get caught between the steering wheel and the airbag.
  - Alternately tighten the right and left TORX bolts so that the clearances between the steering wheel and horn pad are equal on both sides. Torque the TORX bolts to 10 N·m (7.2 lbf·ft).
  - TORX bolts are coated with loctite, so they cannot be reused. When installing the airbag, use the TORX bolts included in this kit.

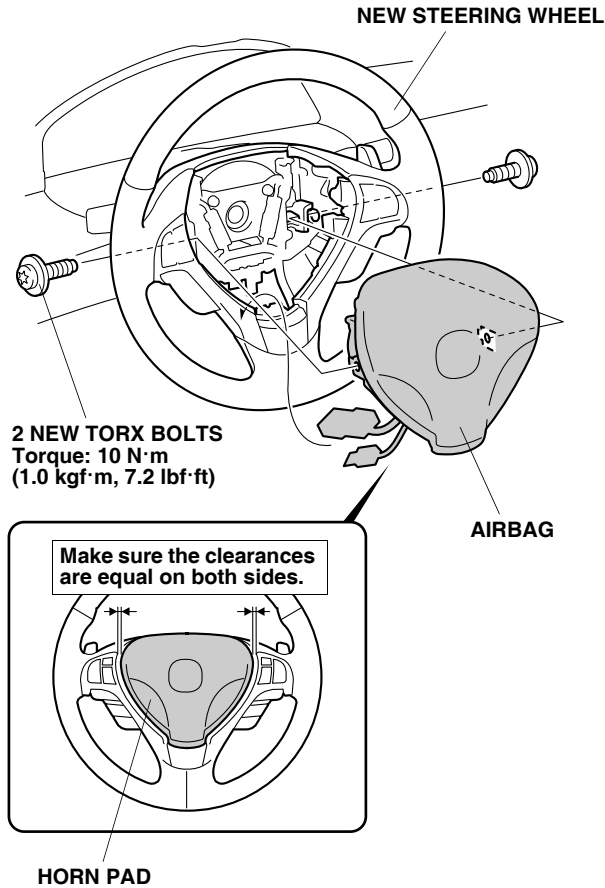

25. Reconnect the horn connector and the airbag connector. To reconnect the airbag connector, hold the pawl-side connector, and push on the back of the sleeve-side connector. Do not hold the sleeve, the sleeve is pushed back by the pawl as the two airbag connectors mate.

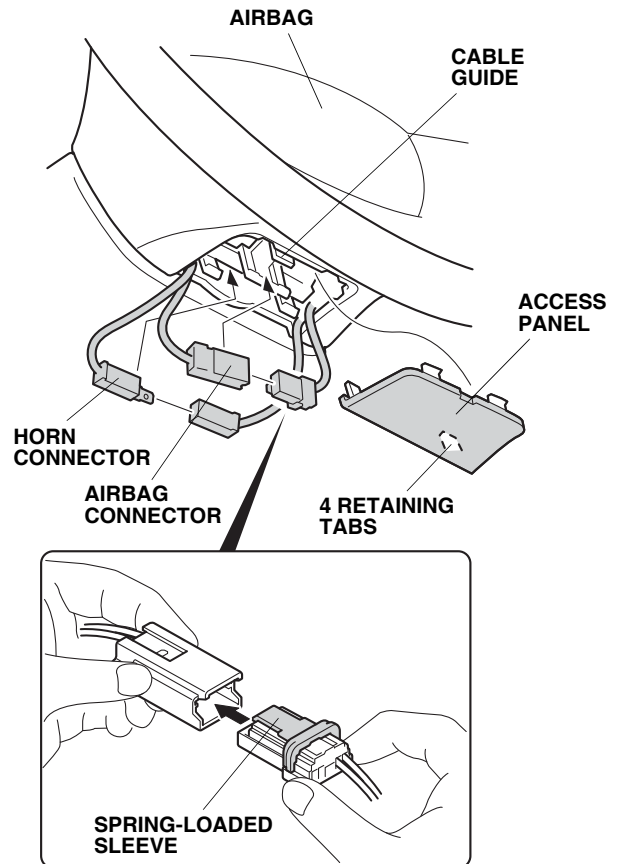

26. Secure the airbag connector and horn connector to the cable guide.
27. Reinstall the access panel.
28. Check that all wire harnesses are routed properly and all connectors are plugged in.

29. Reconnect the negative cable to the battery.
30. Connect the HDS, and clear the DTCs.
31. Inspect the following items. If the items do not operate properly, perform the troubleshooting in the service manual.
  - Turn the ignition switch to ON; the SRS indicator should come on for about 6 seconds and then go off.
  - Make sure the horn works.
32. Press and hold the radio power button for two seconds to restore the radio and navi (if equipped) system functions.
33. Reset the clock (vehicle without navigation).
34. Make sure the steering wheel is in the straight-ahead position with the front wheels. If the spoke angle of the steering wheel is not in the straight-ahead position with the front wheels, adjust the front toe.